

# M.W. Amplitude Modulator

Stef Niewiadomski



Enjoy your listening as you used to through your radios of bygone eras!

**A** POPULAR pastime amongst amateurs is renovating and listening to old valve or transistor radios. These radios are usually a.m. only, tuning the Medium and Longwave bands, with maybe a Shortwave range. With the advent of high-quality stereo f.m. transmissions on VHF, and more recently DAB radio, a great deal of music and other material is unavailable to these radios. For those who like this “antique” sound quality, this situation is to be regretted!

The unit described here helps to make amends for this – it takes its input from the audio output of an f.m. or DAB receiver, or other modern audio source, and regenerates it into an a.m.-modulated format in the Medium Wave band suitable for feeding into the aerial input of your old radio. No modifications to the signal source equipment are needed.

## Oscillator Circuit

The circuit diagram in Fig.1. shows the variable frequency oscillator (VFO) and buffer stages of the unit. Transistor TR1 forms a conventional Hartley oscillator tuned by variable inductor L1, in parallel combination with fixed capacitor C4 and variable capacitor VC1.

The adjustable core of L1 provides a coarse tuning setting and VC1 allows fine frequency tuning of about  $\pm 50\text{kHz}$ . Small variable capacitors are rather expensive, so VC1 can be omitted if preferred, and all frequency adjustment made via L1, although less easily.

Transistor TR2 forms a buffer stage to isolate the VFO from the load of the Modulator/Power Amplifier (PA) board. Resistor R2 and capacitor C6 decouple the supply for TR2. The output from TR2 is developed across r.f.c. L2 in conjunction with C7 and R4. It is a.c. coupled by capacitor C8 and taken via miniature r.f. coax cable to the Modulator/PA board.

In the prototype, 2N3819 *n*-channel f.e.t.s were used for TR1 and TR2, but since the frequency of operation is low, almost any other *n*-channel f.e.t.s can be used. However, take care to check their pinouts since they may differ.

Radio frequency choke (r.f.c.) L3, plus resistor R1, Zener diode D1, and capacitors C1 and C2 produce a noise-free, stabilised supply for TR1.



## Modulator Circuit

The circuit diagram for the Modulator/PA and lowpass filter stages is shown in Fig.2. The signal from capacitor C8 in Fig.1 is brought into r.f. level control VR1, a.c. coupled by C9 and fed to the base (b) of transistor TR3, which is d.c. biased to 0V by R6. The collector voltage of TR3 is supplied by the modulated output

from audio amplifier via the r.f. blocking components L4 and C21, more on which presently.

The output from the collector (c) of TR3 is taken to a lowpass filter via blocking capacitor C11. Under quiescent conditions, that is with no audio input to IC1, TR3's collector sits at about mid-rail voltage (6V). This relatively low collector voltage is not ideal for linear amplification and the waveform at this point is distorted and

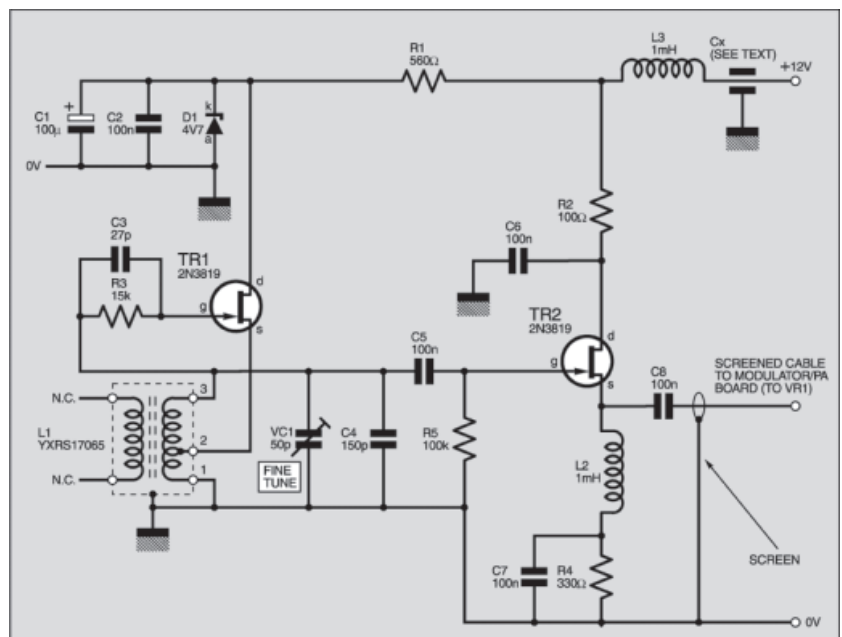

Fig.1. Circuit diagram for the variable frequency oscillator (VFO) and buffer stages.

harmonic-rich, hence the need for a low-pass filter. The audio quality was found to be very good from the radios with which the unit was tried.

Components L5, L6 and C12 to C15 form a 5-pole Chebyshev 1dB lowpass filter with a cut-off frequency of about 700kHz. This is used to give a fast roll-off to attenuate the unwanted harmonics generated by TR3.

A simple output attenuator is formed by potentiometer VR2 and switch S1. When S1 is closed, VR2's selected setting affects the amplitude of the output signal. When S1 is open the setting of VR2's wiper has almost no effect on the output signal level. The output from the unit with the attenuator set to minimum attenuation is about 600mV peak-to-peak.

Two inputs to IC1 have been provided in a simple stereo mixer format, via C16 and R8 for one channel, and C17 plus R9 for the other, combining at the "top" of modulation level control VR3. The combined signal is a.c. coupled to IC1 via C18. Inductor L7 attenuates any r.f. picked up along the connecting cable.

The mono output from IC1 pin 5 modulates the r.f. signal from the oscillator circuit in Fig.1. Resistor R10 and capacitor C22 help to prevent instability at the LM386 output. Inductor L8 prevents any r.f. from the unit radiating from the power line and back into the radio or CD player-driving the unit.

Normally pins 1 and 8 of an LM386 amplifier are connected via a 10uF capacitor. This has the effect of raising the gain of the LM386, but in this design it has been omitted since there is already plenty of gain available to modulate TR3. Adding the capacitor would have the detrimental effect of increasing the hiss of the circuit. Nonetheless, the p.c.b. includes tracking for this capacitor, so the constructor can experiment if desired.

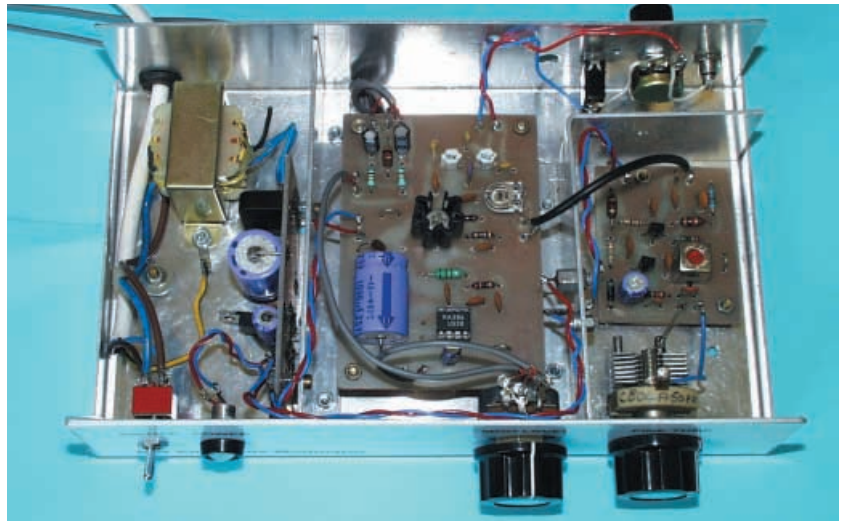

### Power Supply

The M.W. Amplitude Modulator can be powered directly from a 12V battery. However, it may alternatively be powered from a mains driven power supply, such as that shown in Fig.3, which provides a regulated output of 12V d.c.

Mains power is input via switch S2 to mains transformer T1. The secondary 12V a.c. output is rectified by REC1 and smoothed by C23. It is then regulated down to 12V d.c. by IC2, whose output is smoothed by C24 and C25. Power-on indication is provided by l.e.d. D2, buffered by R11.

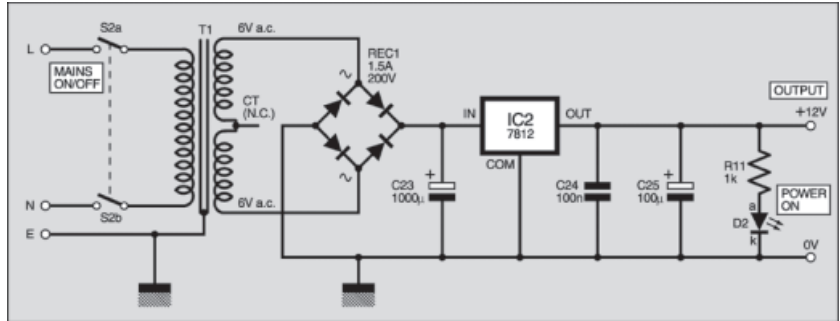

Fig. 3 Suggested mains power supply circuit diagram.

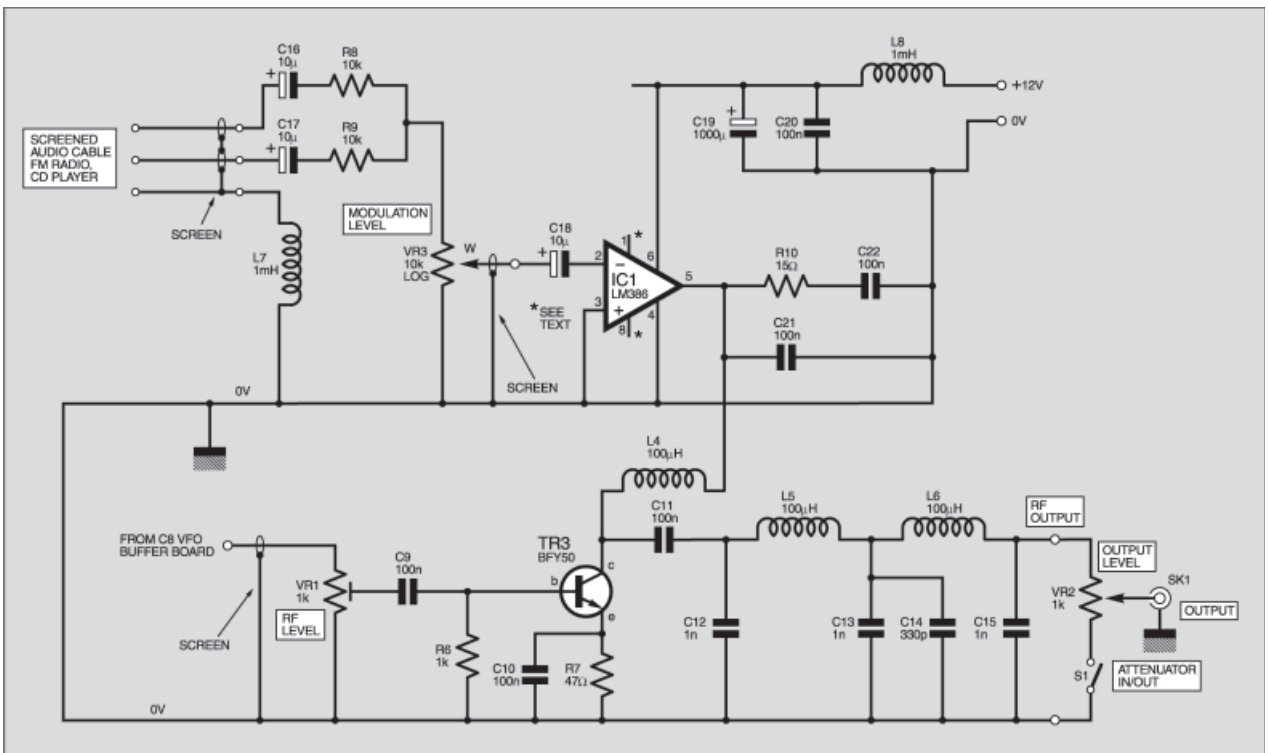

Fig.2. Circuit diagram for the Modulator/PA stages for the M.W. Amplitude Modulator

## M.W. AMPLITUDE MODULATOR - CIRCUIT BOARD CONSTRUCTION AND WIRING

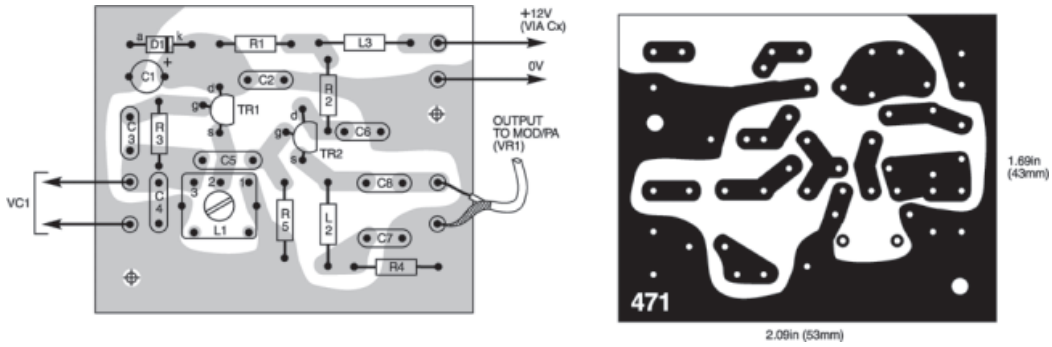

Fig.4. Printed circuit board topside component layout, wiring details and full-size underside copper foil master for the VFO. Keep the wires to the Fine Tuning capacitor as short as possible.

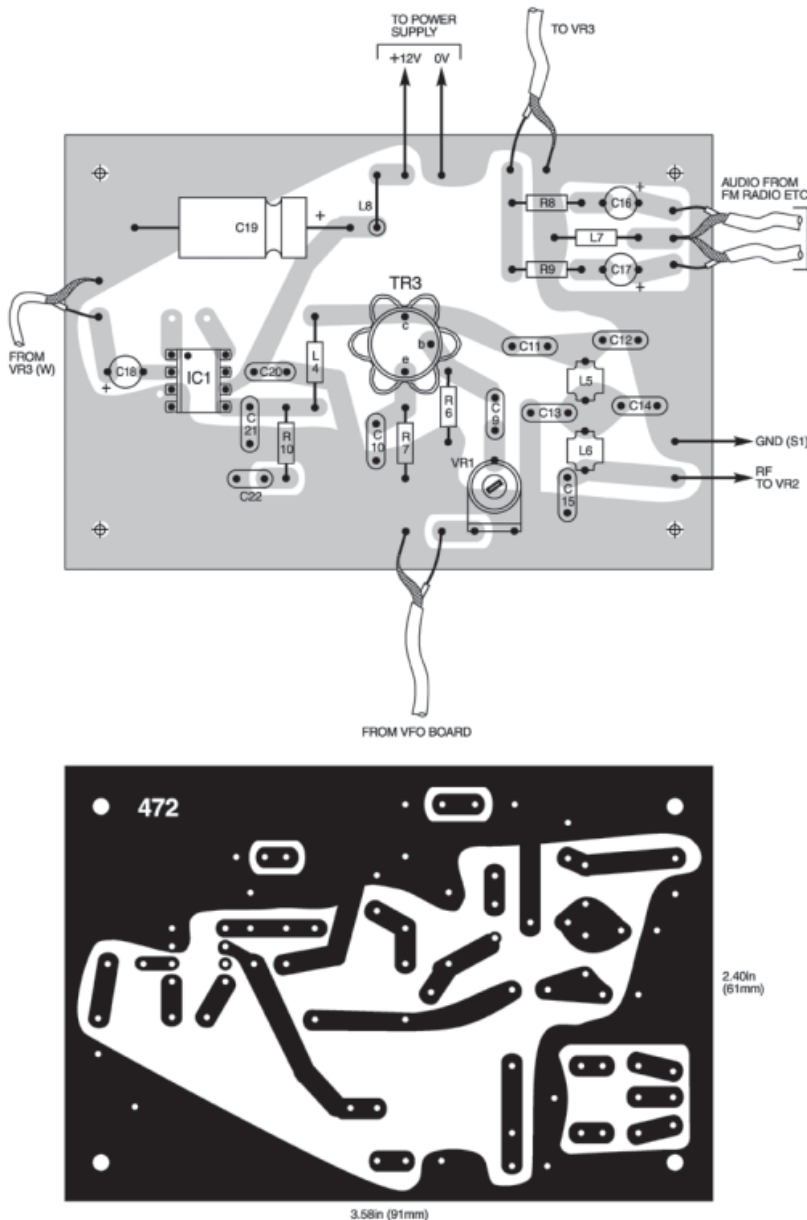

Fig.5. Modulator printed circuit board component layout, wiring and full-size copper foil master pattern.

### Construction

Note that the mains power supply should only be built by those who are suitably qualified or supervised.

Also note that in the UK, and in many other countries, it is an offence to transmit on the Medium Wave without a broadcast license, even at the low powers generated by this unit. Care should therefore be taken to eliminate any radiation by connecting the unit to the MW radio using screened cable.

## COMPONENTS

### Resistors

R1	560Ω
R2	100Ω
R3	15k
R4	330Ω
R5	100k
R6	1k
R7	47Ω
R8, R9	10k (2 off)
R10	15Ω
R11	1k

All 0.25W 5% metal film or better.

### Potentiometers

VR1	1k min. carbon preset
VR2	1k rotary carbon, lin
VR3	10k rotart carbon, log

### Capacitors

C1, C25	100μ radial elect. 16V (2 off)
C2, C5 to C11	100n ceramic disc
C20 to C22, C24	(12 off)
C3	27p ceramic disc
C4	150p ceramic disc
C12, C13, C15	1n ceramic disc (3 off)
C14	330p ceramic disc
C16 to C18	10μ radial elect. 16V (3 off)
C19	1000μ radial elect. 16V
C23	1000μ axial elect. 25V
VC1	50pF variable
CX	Feedthrough type

### Semiconductors

D1	4V7 400mW Zener diode
D2	red l.e.d.
IC1	LM386 power amp i.c.
IC2	7812 +12V 1A volt age regulator

See  
**SHOP  
TALK**

Fig.7. Layout of components and interwiring inside the metal case.

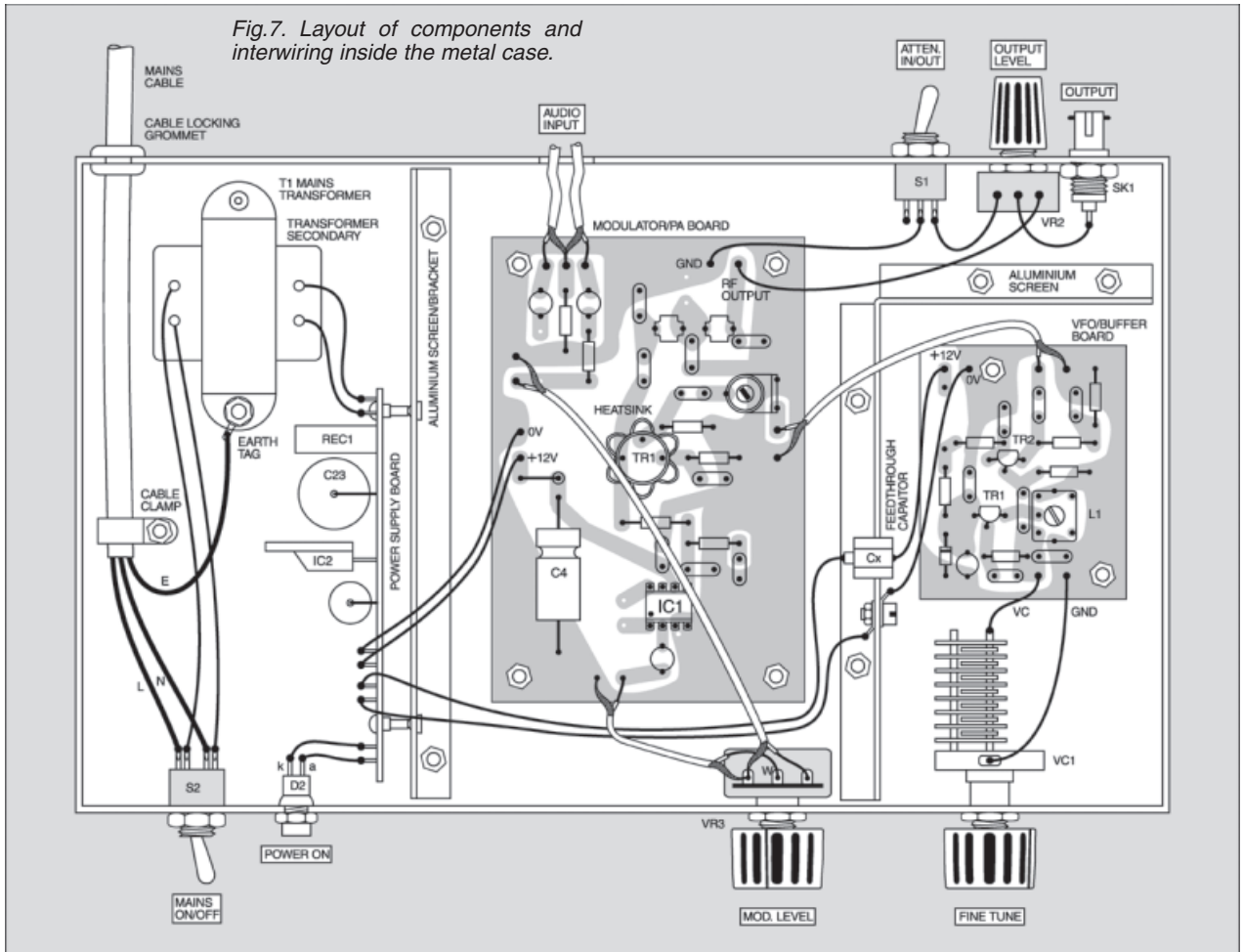

- |                      |  |
|----------------------|--|
| REC1                 | 200V 1-5A bridge rectifier                         |
| TR1, TR2             | 2N3819 <i>n</i> -channel f.e.t. (see text) (2 off) |
| TR3                  | BFY50 <i>n</i> p <i>n</i> transistor               |
| <b>Miscellaneous</b> |  |
| L1                   | Toko YXRS17065 variable inductor                   |
| L2, L3, L7, L8       | 1mH r.f. choke (4 off)                             |
| L5, L6               | 100 $\mu$ H r.f. choke. Toko 7BS or 7BA (2off)     |
| PL1                  | 3.5mm stereo jack plug                             |
| S1                   | min. s.p.d.t. toggle switch                        |
| S2                   | d.p.d.t. toggle switch, mains rated                |
| SK1                  | phono socket                                       |
| T1                   | min. mains transformer, 6V-0-6V 250mA secondary    |

Printed circuit boards, available from the *EPE PCB Service*, codes 471 (VFO), 472 (Modulator), 473 (PSU); metal case, 200mm x 125mm x 50mm; heatsink for TR3; knobs (3 off); min. screened audio cable; screened r.f. cable; 8-pin d.i.l. socket; terminal pins; 3.5 stereo jack plug capacitor; connecting wire; 3-core mains cable; panel mounting cable lock grommet; cable clip; screening angle aluminium 40mm high; p.c.b. mounting nuts and bolts; solder tag; nuts and bolts; solder, etc

**Approx. Cost**  
**Guidance Only**  
**£36**  
 excl. case

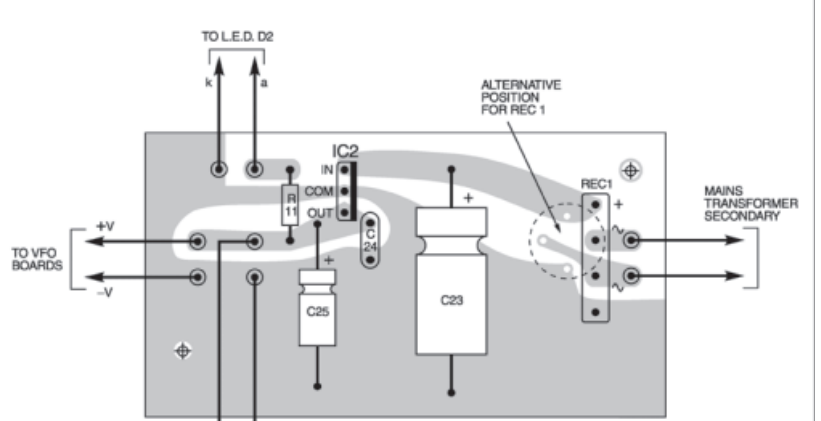
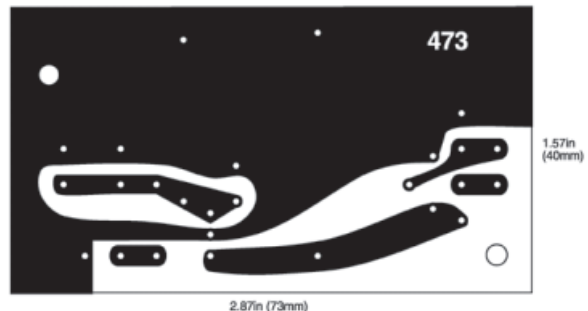

Fig.6. Mains power supply printed circuit board component layout and full-size copper foil master.



The prototype was built on three printed circuit boards (p.c.b.s) and housed in a metal case to screen the circuit. These boards are available from the *EPE PCB Service*, codes 471 (Modulator), 472 (Output) and 473 (PSU).

Component layout and tracking details for the boards are shown in Fig.4 to Fig 6. Assemble the components in ascending order of size, taking care to correctly orientate the semiconductors and electrolytic capacitors. Insert 1mm terminal pins to facilitate inter- and off-board wiring.

## Assembly

The general arrangement of the boards and chassis-mounted components in the case is shown in Fig.7.

The mains p.s.u., if used, must be mounted in an area of the case separated by a metal partition, to which the p.s.u. board is securely mounted.

A mains-rated double-pole switch must be used for S1 and the Earth wire of the 3-core mains lead must be securely connected to the metal case via an earth tag. The mains lead must pass through the rear of the chassis via a cable-locking grommet.

The transformer is mounted on the chassis, close to the rear of the case as shown. The power supply p.c.b. is mounted on its side on a piece of angle aluminium (40mm high x 120mm long). It must be securely mounted on the partition.

A similar piece of aluminium angle was used to enclose the VFO/Buffer board along with the Fine Tuning

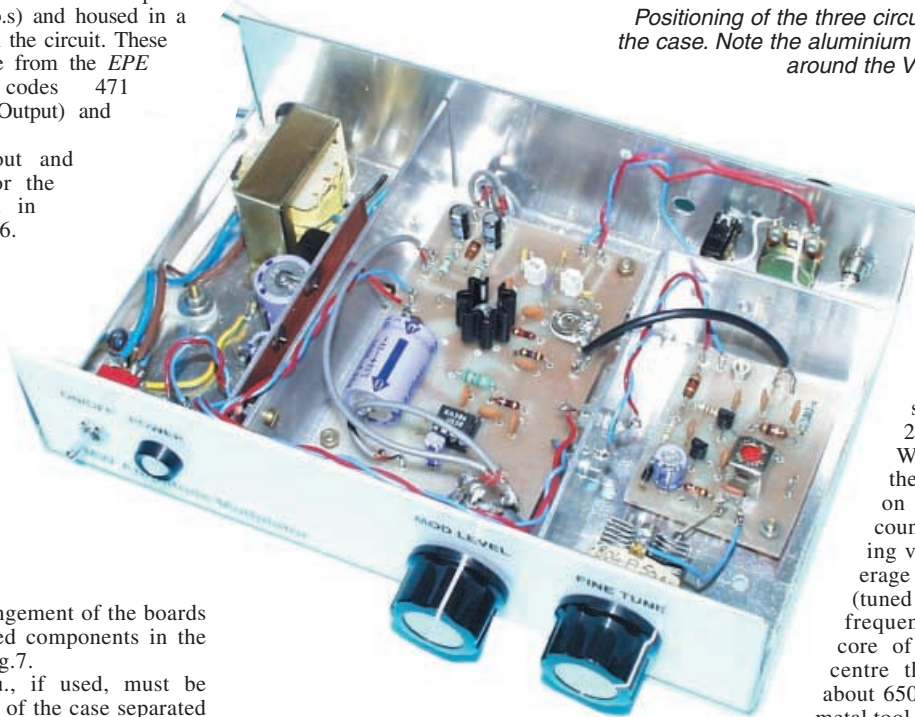

*Positioning of the three circuit boards inside the case. Note the aluminium screen partition around the VFO/Buffer p.c.b.*

If an oscilloscope is available check the output from the VFO/Buffer board. This should be about 2V peak-to-peak. While measuring the VFO frequency on a frequency counter, or monitoring via a general coverage or MW receiver (tuned to the required frequency), adjust the core of inductor L1 to centre the frequency at about 650kHz. Use a non-metal tool for this. Rotating VC1 should vary the frequency between 600kHz and

700kHz.

capacitor VC1. An optional screw-in feedthrough capacitor (Cx) feeds the +12V supply to the board and a piece of miniature coax cable connects the Buffer stage output to the PA stage via a hole in the aluminium screen.

## Setting Up

Thoroughly check all the boards and the inter-board wiring. Switch on the mains power and check that l.e.d. D2 lights and that the power supply's output from regulator IC2 is close to +12V. Immediately disconnect the power and recheck your assembly if there is a problem.

## Modulation

Set VR1 on the Modulator board to about mid-way (the setting does not seem to make a big difference to the output waveform), and the Modulation Level control VR3 to minimum. Attach the scope to socket SK1 and check for a good sine wave at the VFO frequency.

If you have an a.f. signal generator, connect it to the audio input of the Modulator board and slowly advance Modulation Level control VR3. The output waveform should show the classical amplitude modulated waveform. If a scope is not available check the frequency of the unit's output on a frequency counter or MW receiver. It should be the same as the VFO frequency. Be extra careful not to select a harmonic frequency.

## In Use

When all seems to be satisfactory, set the attenuator network control VR2 to maximum. Connect the unit's output at socket SK1 to the aerial input of a MW receiver via screened cable. Connect the signal inputs via stereo plug PL1 to the headphones output of an audio source. This should automatically turn off the source's internal speaker. Adjust the source volume control to a reasonable listening level.

Tune the receiver to the unit's frequency, about 650kHz, and adjust the Modulation Level control until the audio can be heard. Advance this control to just below the level when distortion starts. This is when the unit is being over-modulated. The attenuator control may need adjustment depending on the sensitivity of the MW receiver. Fine-tuning of the unit's frequency can be done using variable capacitor VC1. □

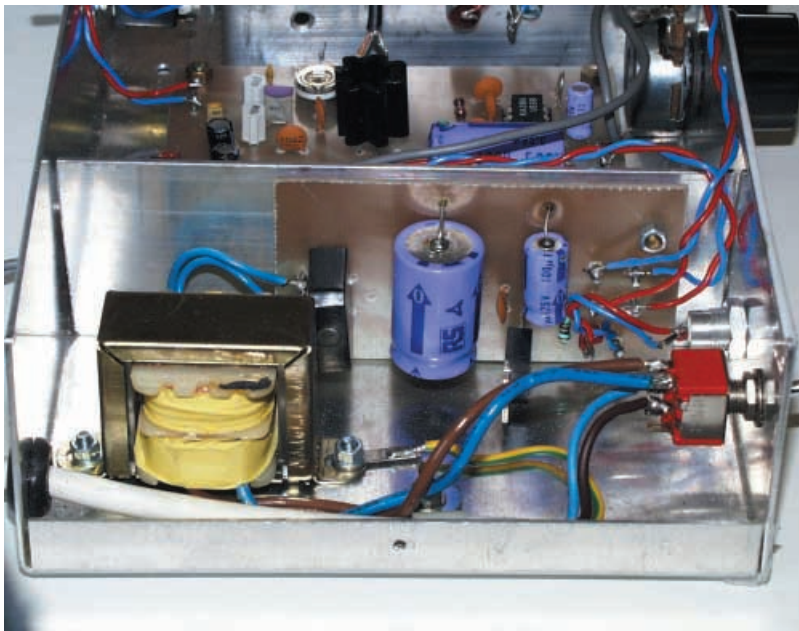

*Close up view of the power supply components. Make sure the circuit board is bolted securely to the side of the screening panel. Note also the Earth solder tag bolted under one of the transformer fixing bolts.*